



Connection to CPAP

The Qtube should be connected to your CPAP by placing the one end of the supplied eight (8) inch tube to either end of the Qtube and placing the other end of this tube to the outlet of your CPAP device. Your existing CPAP tubing should be attached to the opposite end of the Qtube.

The Qtube is designed to be placed inline with your existing CPAP tubing as close to the airflow discharge of your CPAP as possible to ensure maximum effectiveness.

Replacement Interval

Your Qtube should provide approximately fourteen (14) days of continuous use before requiring a replacement of the inner foam sound baffling material. (Part #HD60-2550) Replacement procedures are on the reverse side of these instructions.

Qtube™

Qtube
Part # HD60-2500
Quantity – 1

Manufactured by:
Human Design Medical, LLC
Charlottesville, VA 22902

Qtube is a trademark of Human Design Medical, LLC.
Patent Pending.

Qtube Insert v1 07022015
#40-0046 Rev. A

Package Contents

- one ready to use (1) Qtube with already installed inner foam baffling materials
- one (1) eight (8) inch slim-style tube for connecting the Qtube to your CPAP
- one (1) Qtube Replacement Kit (Containing: O-ring, foam baffling material, plastic baffling sleeve)

Intended Use

The Qtube is a single patient reusable accessory designed to reduce acoustic noise which may be transmitted to the patient mask through the CPAP tube. The Qtube has standard end fittings and may be used with any standard (22mm) or slim-style (15 mm) CPAP tube.

Warnings

HDM recommends removing the inner foam sound baffling material from the unit to allow it and the interior of the unit to dry thoroughly after each use.

The Qtube should always be kept dry and particular care should be taken to ensure that unit is completely dry after replacement of inner foam sound baffling material.

The Qtube should not be washed with soap or other cleaning agents but may be rinsed with water and dried thoroughly.

The Qtube is designed specifically for use with HDM's Heat Moisture Exchange Unit (and other similar non-water based heat moisture exchange devices).

Warning: In the event that you chose to use your Qtube with a heated water humidifier, HDM strongly recommends inspecting the interior of the unit daily and replacing the inner foam sound baffling material at least every fourteen (14) days of use.

Qtube™ Disassembly and Maintenance

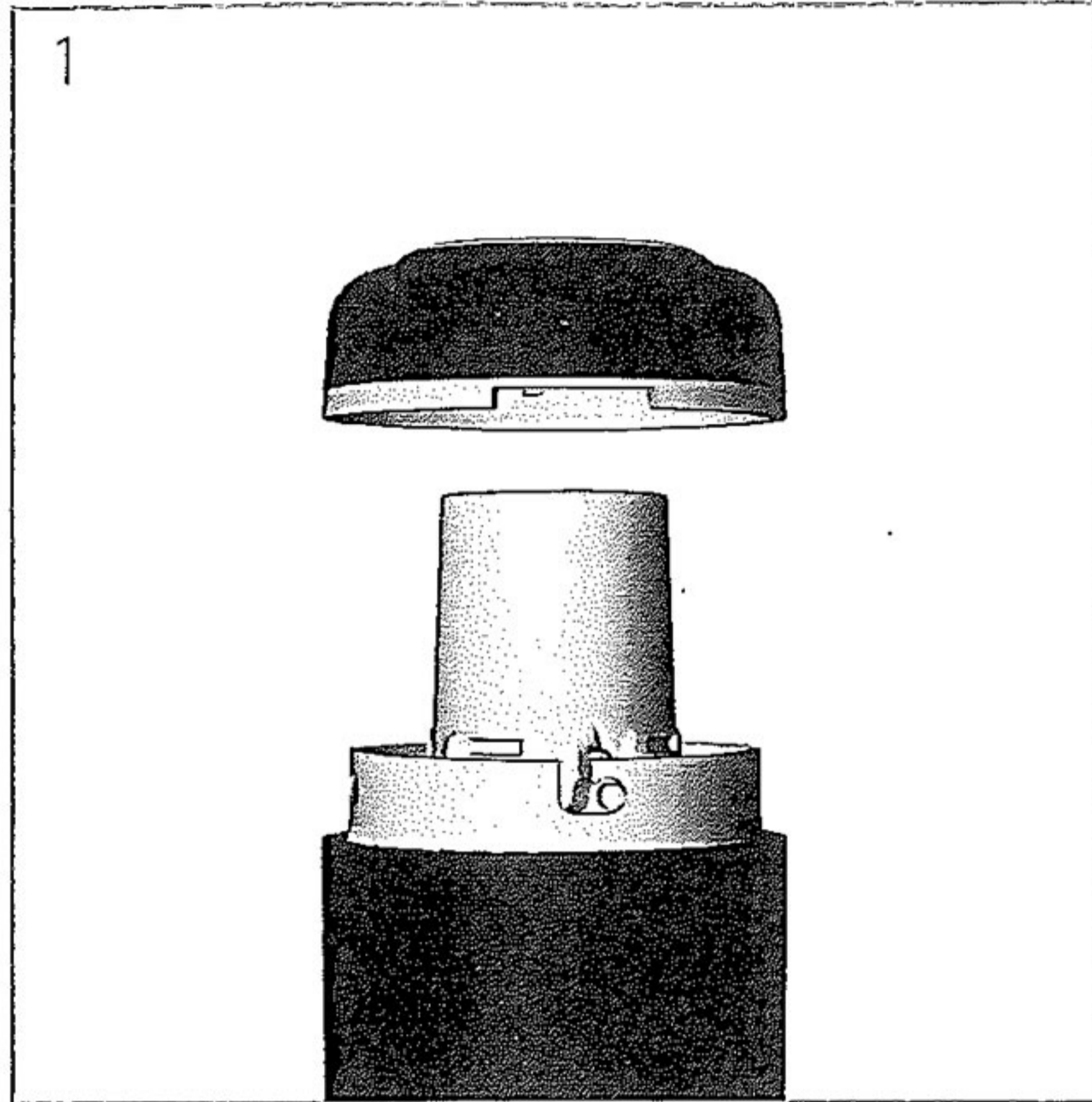

Remove the Retaining Clip of the Qtube by placing the tip of your finger in the slot (see Fig. 1) and pull away from the body of the Qtube

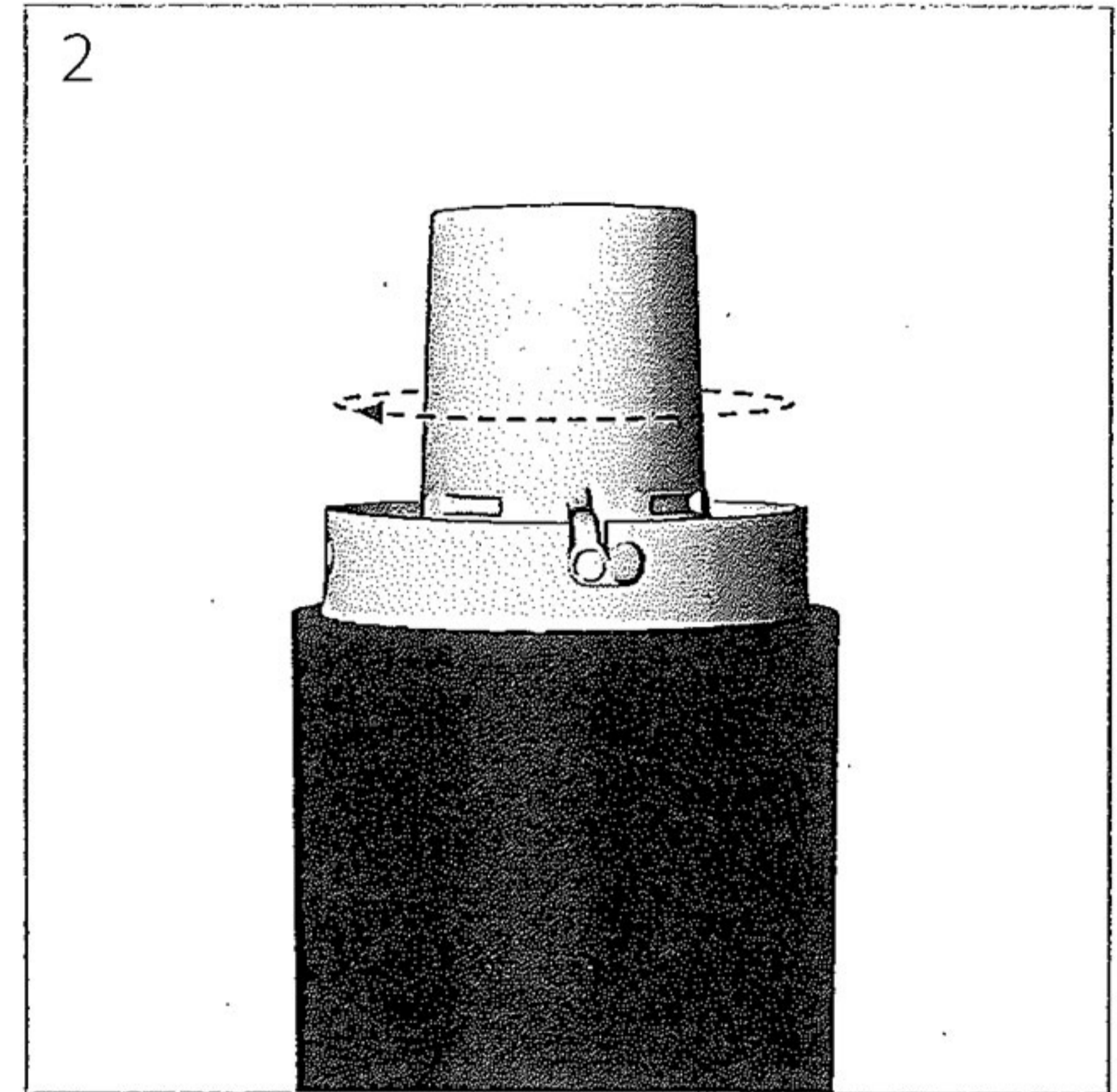

Grasp the top of the End Cap and twist slightly clockwise until the pins line up with the vertical slots on the body of the Qtube.

Note: You may find it easier to turn if you first attach the tube to the End Cap.

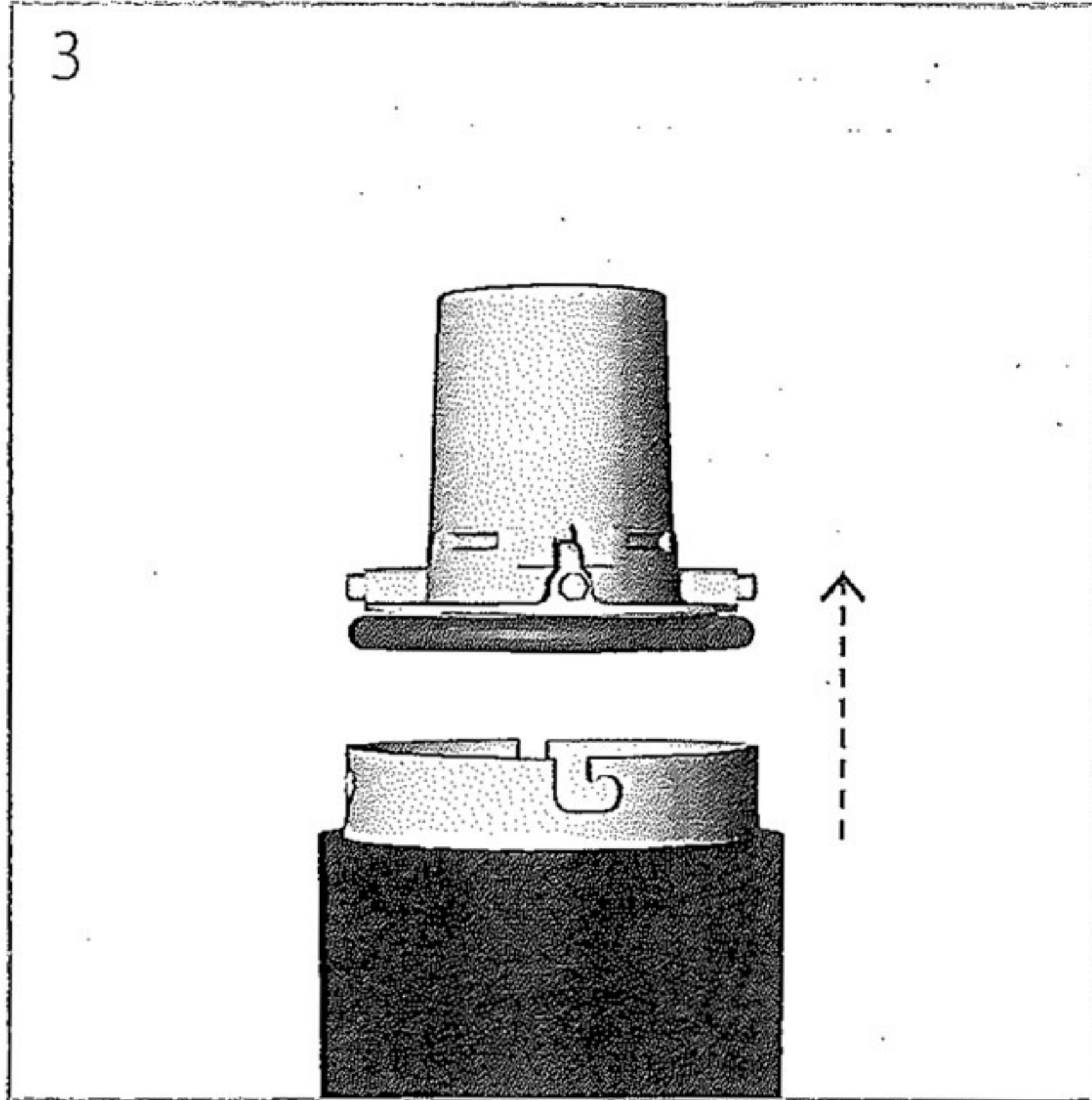

Once the pins are aligned, firmly pull straight upward on the End Cap to remove it

NOTE: The O-ring provides an airtight friction fit to the body of the Qtube so it should provide significant resistance when pulled – it is likely the O-ring will become loose from the groove in the End Cap. Please retain this O-ring as the unit will not function as designed without an O-ring

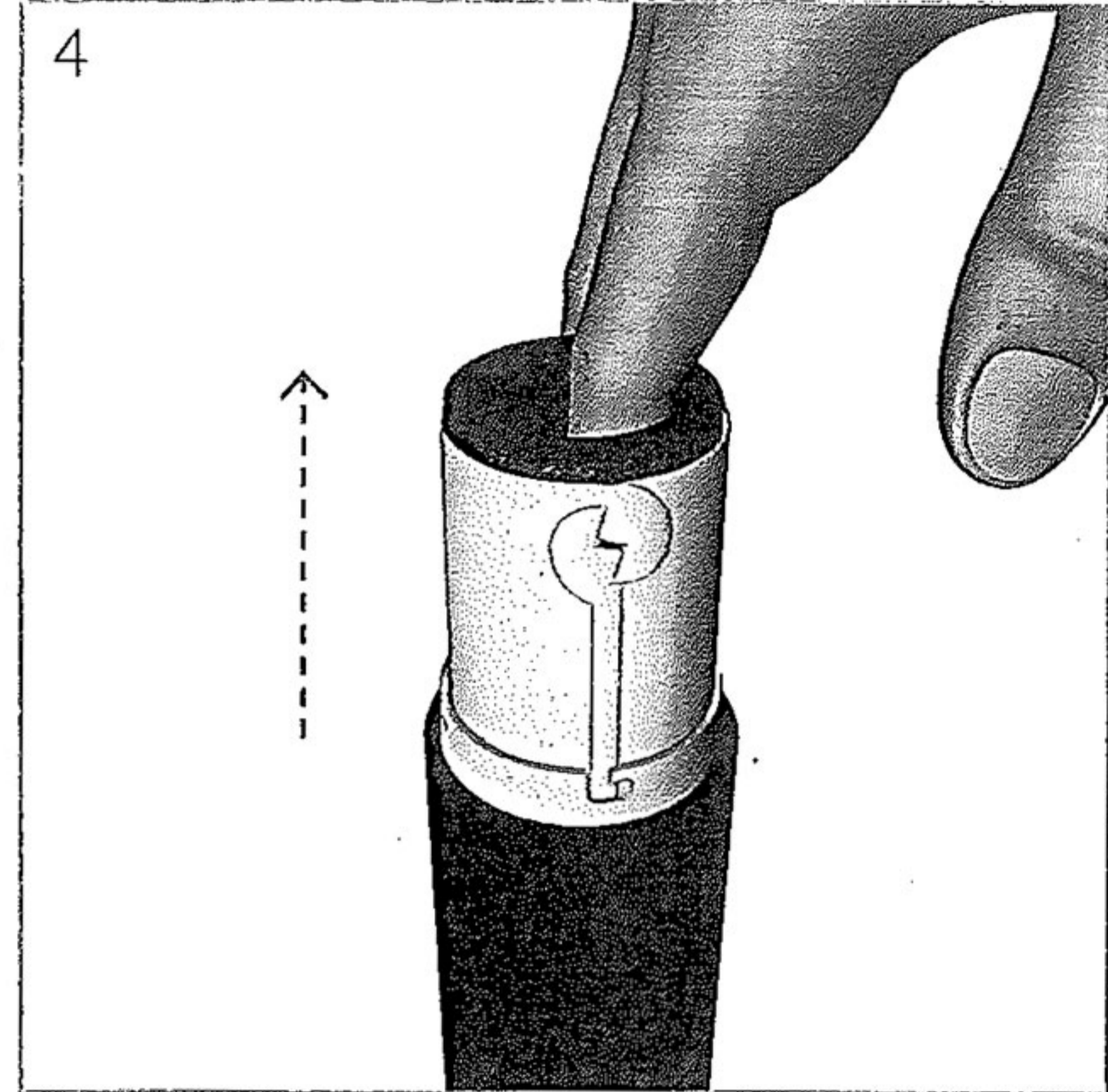

Insert the tip of your finger into the center of the Qtube body and pull the inner foam baffling material upward and out of the Qtube body

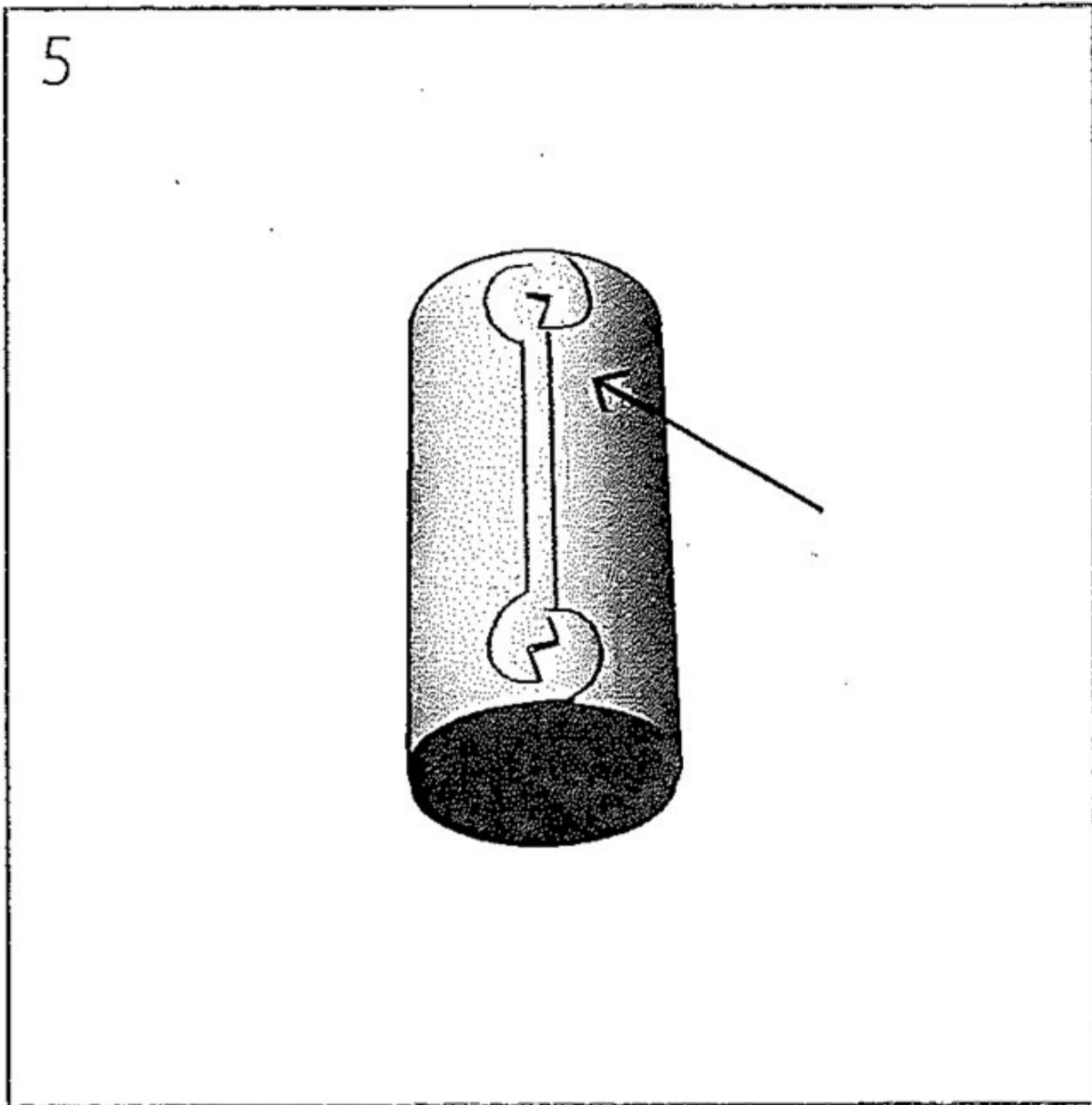

The foam baffle material will be wrapped enclosed within the plastic baffle sleeve. If you are replacing the foam baffle material disengage the locking tabs.

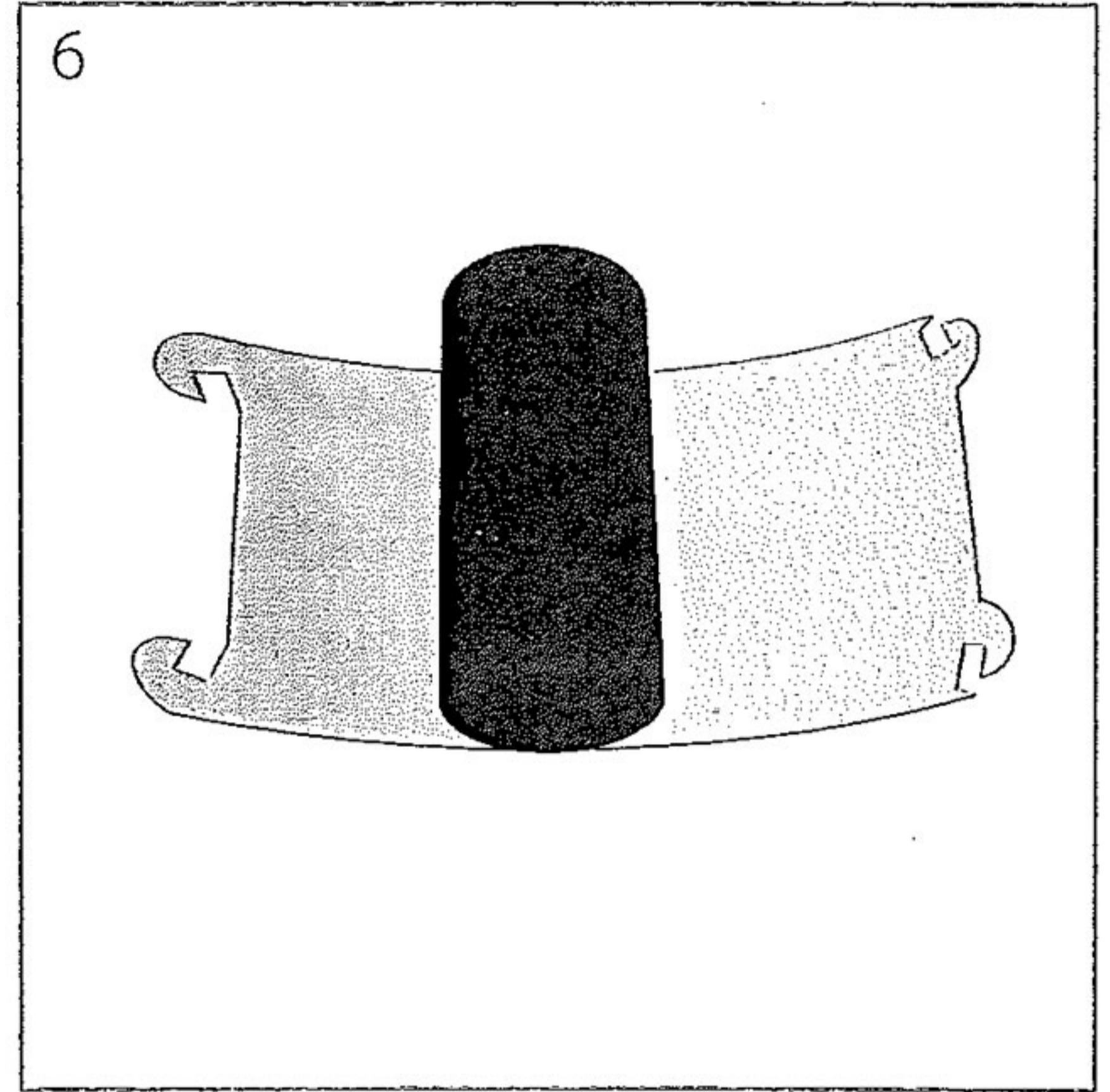

Take the new inner foam baffle material and place this on top of the plastic sleeve liner. Roll the foam material so that the edges of the plastic sleeve liner meet and the tabs are adjacent to each other. Once the tabs are aligned, slip one of the tabs past the other such that they interlock.

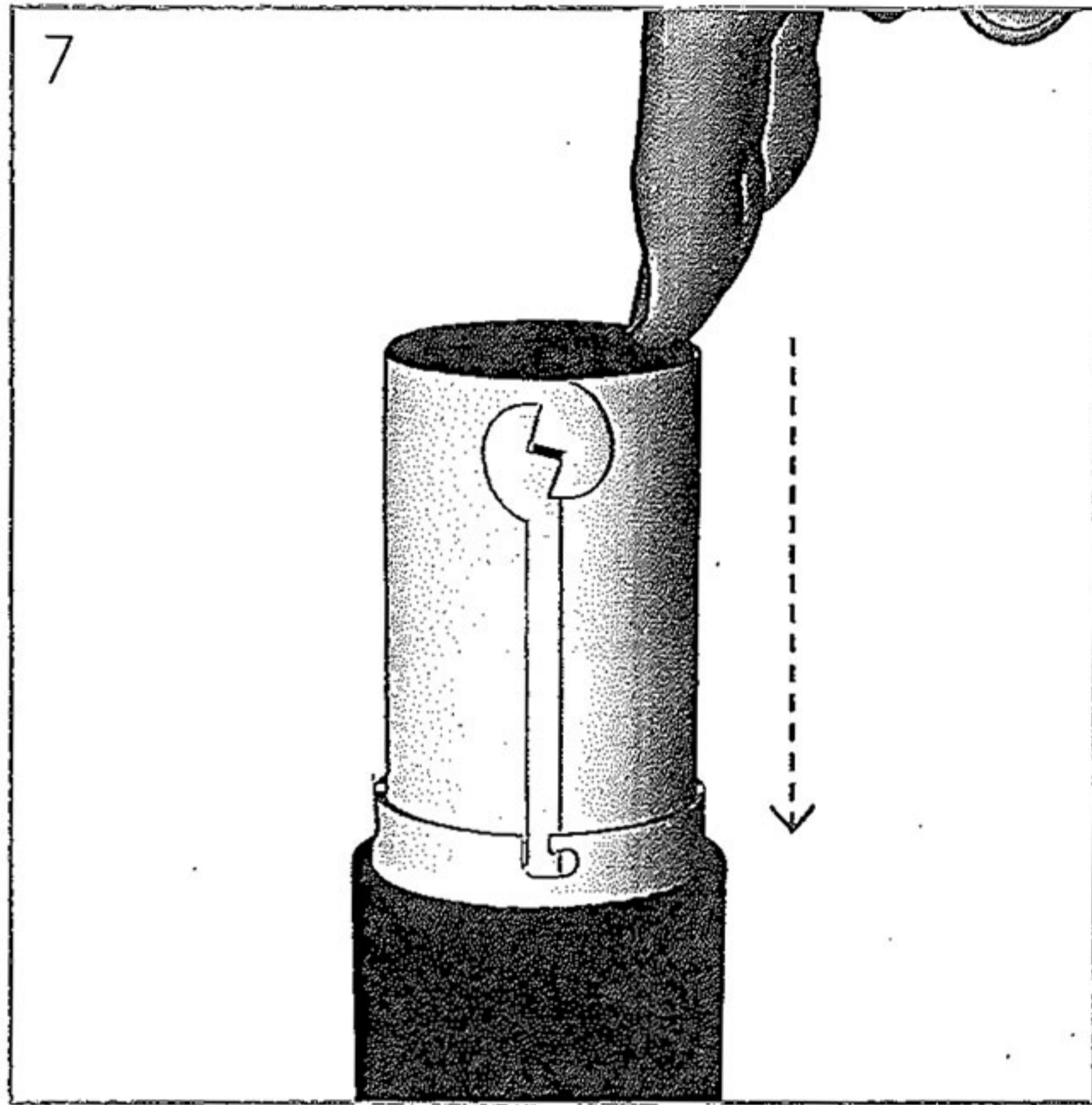

Insert the rolled inner foam baffling material into the body of the Qtube and push all the way until the bottom of the material contacts the opposite end of the Qtube body. You should be able to look down the center of the material and see that the center is clear and that there are no obstructions to the airflow.

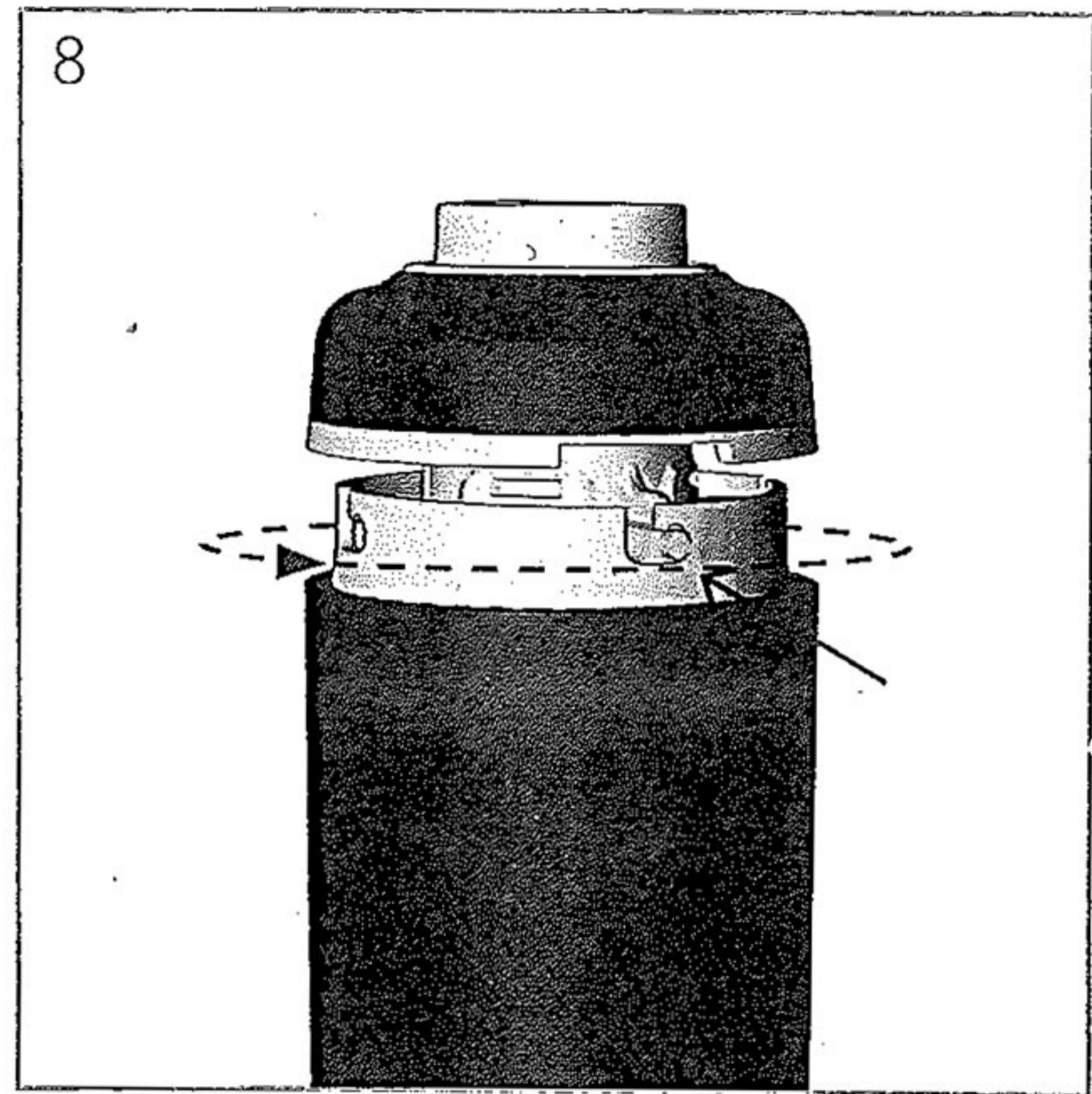

To reassemble, ensure that the O-ring is seated in the groove at the bottom of the end cap, align the pins on the end-cap, and push downwards, and twist slightly counter-clockwise until the pins return to the locked position. Finally, replace the retaining clip by firmly pressing straight down until it "clicks" into place.

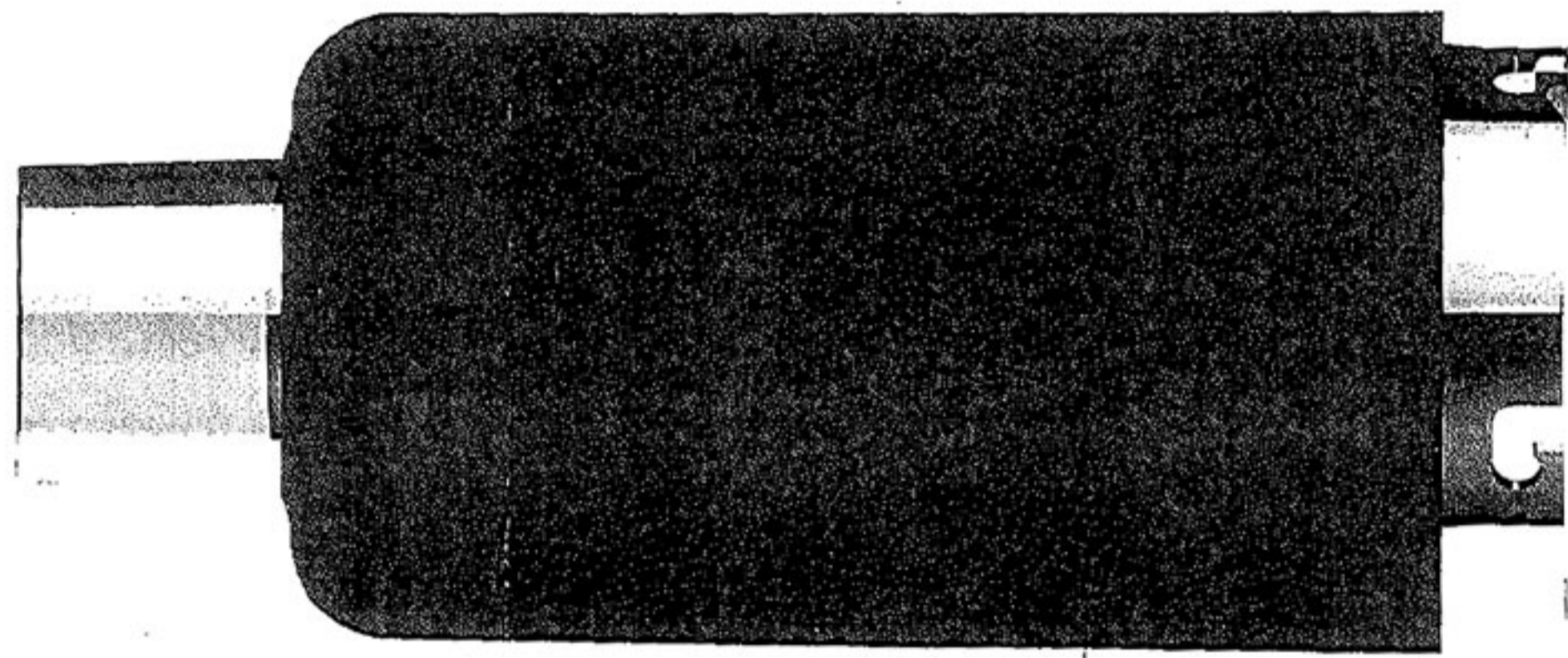

Body

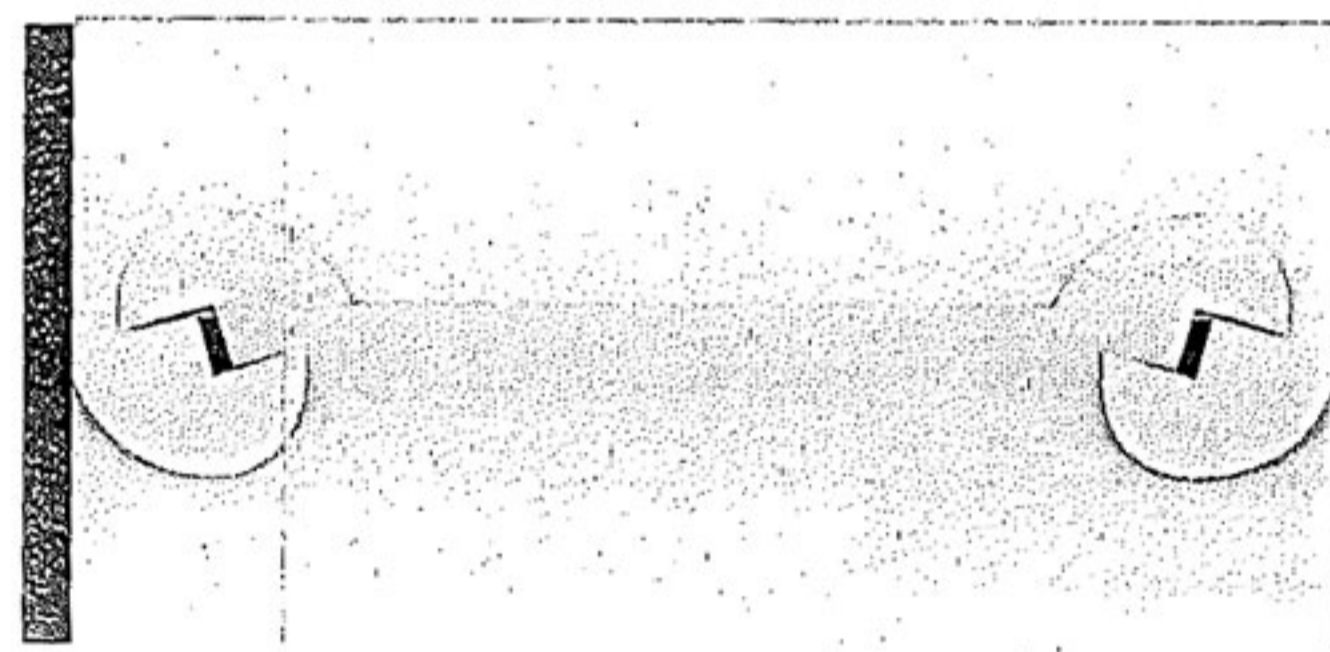

Inner Foam/ Baffling Material



O-Ring

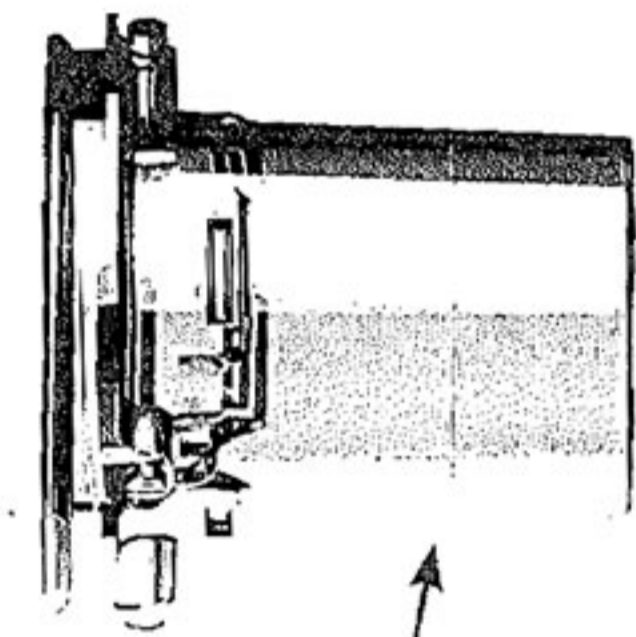

End Cap



Retaining Clip