



DirectHome
MEDICAL

CLICK TO LEARN MORE

SoClean
Travel CPAP Sanitizer **2Go**[®]

User Guide



Thank You!

Thank you for your purchase of the SoClean 2 Go, the world's first portable CPAP sanitizing device. The SoClean 2 Go features the same easy, effective, and safe approach to sanitizing as the original SoClean—only now it's completely portable.

Please familiarize yourself with this manual and the operation of the unit. After a few simple steps, you'll find that keeping your CPAP equipment clean has never been easier, even on the go!

Better Rest Solutions is committed to developing innovative and safe ways to improve the health and well-being of our customers. It is our hope that the SoClean 2 Go will do just that for you.



Contents

1. Safety and Technical Specifications	4
2. Included with Your SoClean 2 Go	5
3. Important Supplies	6
4. Getting Started	7
5. Using Your SoClean 2 Go	11
6. Maintaining Your SoClean 2 Go	13
7. FAQ	14

Safety and Technical Specs



DANGER: Keep away from water sources including rain, bathtubs, sinks and pools.



DANGER: Keep away from children. It is not a toy!



DANGER: Do not use in explosive air environments, near gas vapors, or other flammables, etc.



DANGER: Do not place any items on top of SoClean 2 Go Unit, particularly flammables or ignitable items.



DANGER: Never place any living thing (including pets) inside.



WARNING: Do not dismantle the SoClean 2 Go unit.



WARNING: Please be aware that there are sensitive electronics inside the SoClean. If you need to clean your SoClean 2 Go, wipe with a damp cloth. Do not submerge your SoClean 2 Go or use any chemical cleaners.

Weight: 1.3 lbs | **Dims:** 4.3"l x 3.9"w x 4.9"h | **Power consumption:** Battery Operated

Requires: 8 AA Batteries | **Warranty:** 1 year warranty

Included with your SoClean 2 Go

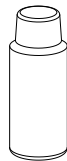
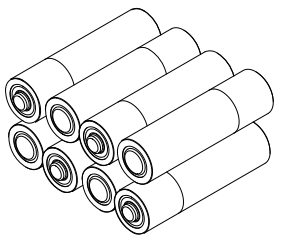
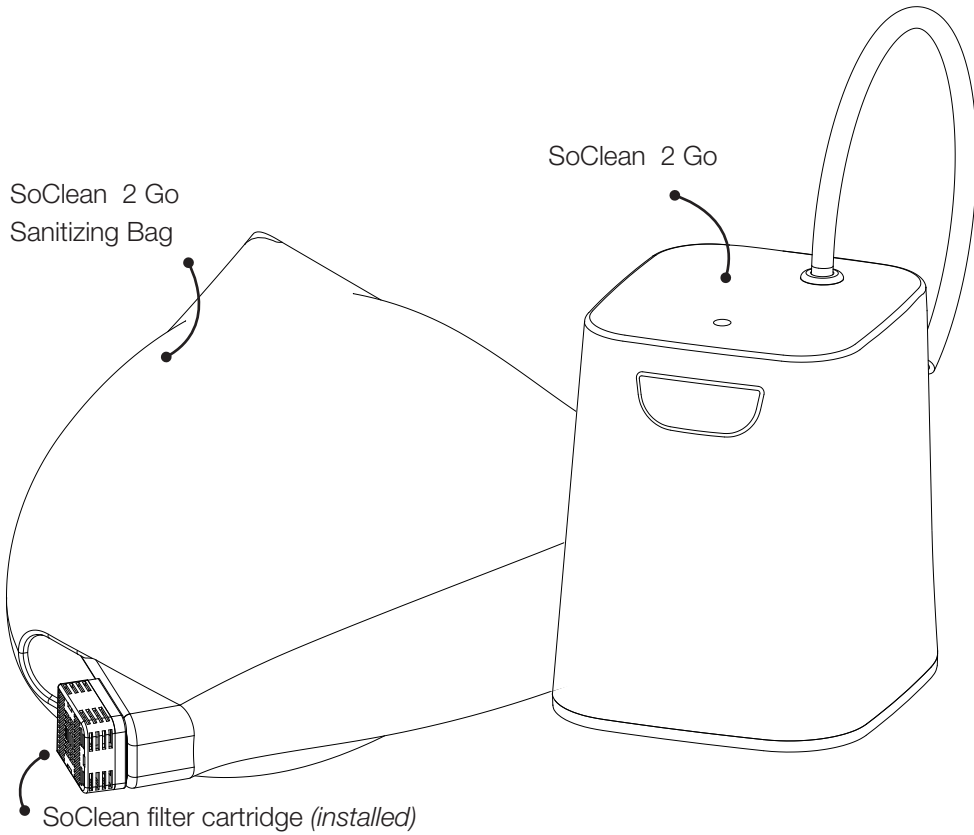

SoClean check valve assembly with injection fitting and hose *(installed)*

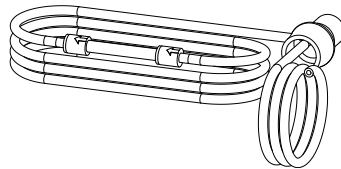

Important Supplies

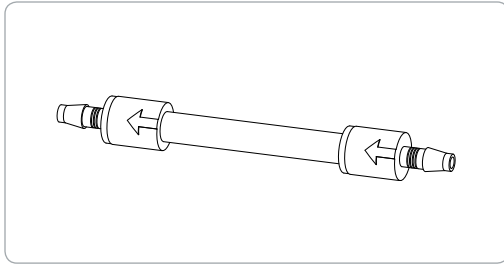

Check Valve Assembly (installed)

Prevents water in your humidifier reservoir from backing up into your SoClean 2 Go machine. If you can see water in the clear tube, replace the check valve assembly immediately. **Replace every 6 months.**

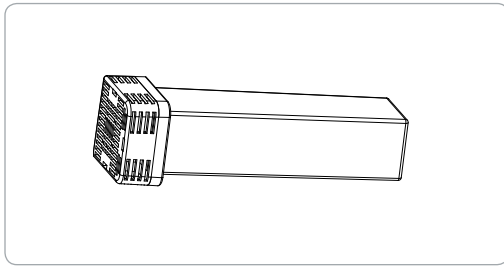

Filter Cartridge (installed)

This filter converts activated oxygen back into normal oxygen. **Replace every 6 months.**



Neutralizing Pre-Wash

This fragrance-free, hypoallergenic cleaning solution neutralizes any pre-existing odors from detergents and removes any residue from the manufacturing process that could react with activated oxygen. Use the pre-wash whenever you hand-wash your CPAP equipment, or any other fragrance-free dye-free dish detergent.

The above items can be ordered directly from your distributor or Better Rest Solutions by phone or by going to www.BetterRestSolutions.com.

Getting Started

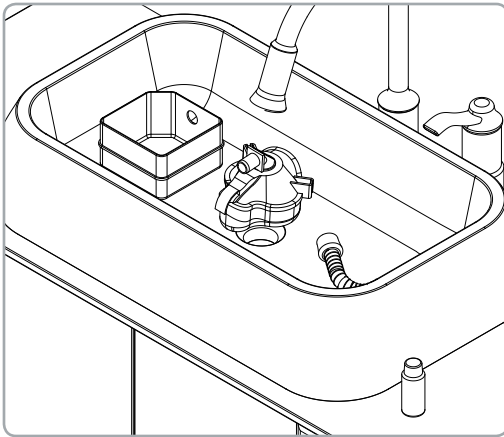

1. Pre-washing Your Equipment

Use two capfuls of the included pre-wash with a gallon of water to wash your CPAP equipment (mask, hose, and reservoir), and then rinse thoroughly with clean water.

Note: The SoClean 2 Go uses no fluids in its operation. The pre-wash is supplied for hand washing your CPAP equipment only.

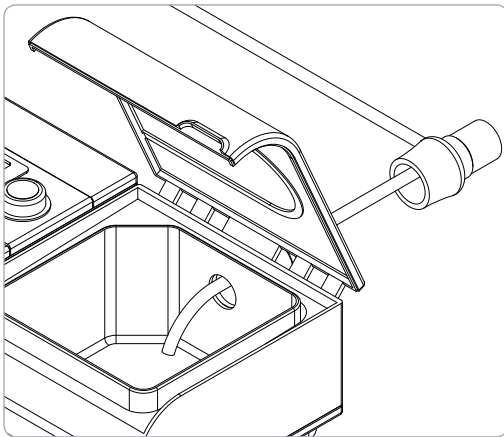

2. Installing the Injection Fitting

With humidifier: Disconnect your CPAP hose from your CPAP machine. Position the injection fitting onto the port of your reservoir, allowing the smaller hose to enter into and rest on or near the bottom of the reservoir. If necessary, trim the injection hose to fit in the reservoir.

Note: If you keep water in the reservoir, it is recommended that you keep the end of the injection hose below the water level.

Getting Started *continued*

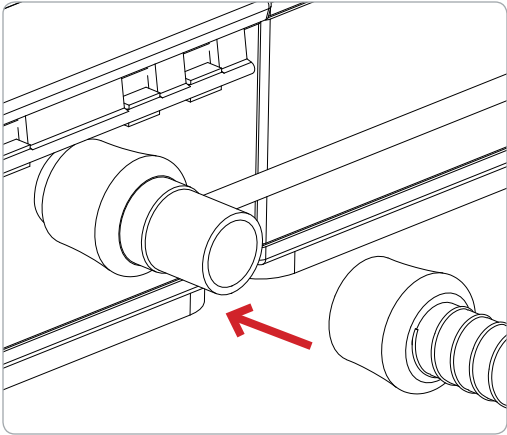

Now, connect your CPAP hose to the end of the injection fitting.

Note: Different reservoirs may require different approaches to hose insertion. If you have difficulty, visit www.BetterRestSolutions.com for information on various humidifier models, or contact Better Rest Solutions directly at 1-866-501-3705.

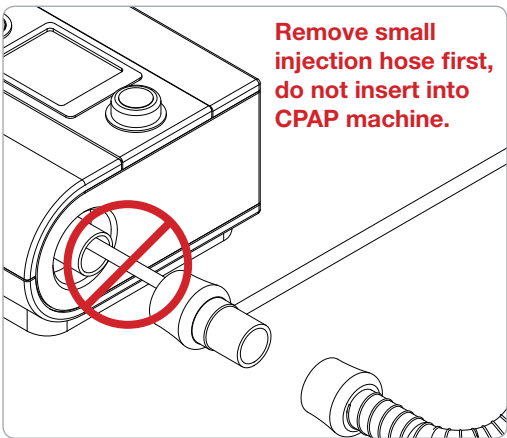

Without humidifier: If you are not using a humidifier, remove the short length of black hose from the inside of the injection fitting by pulling it straight off, and then attach the fitting directly to your CPAP machine. Reconnect your CPAP hose to the end of the injection fitting.

Getting Started *continued*

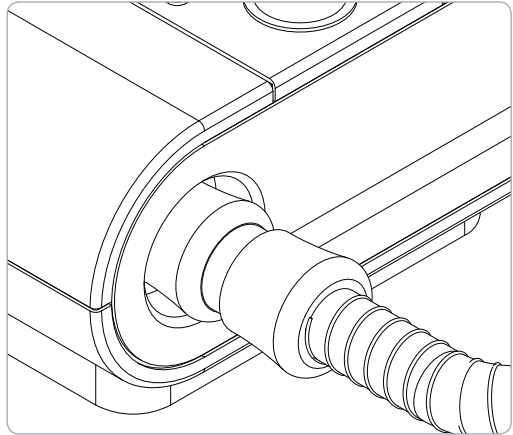
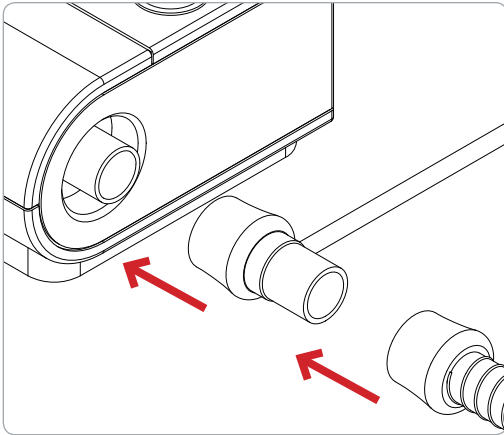

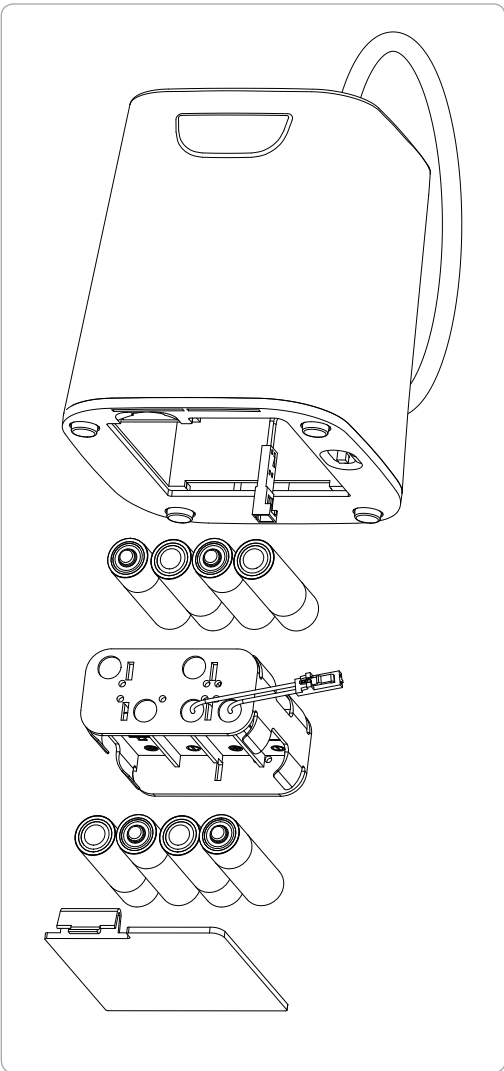

3. Battery Installation

1. Remove the battery compartment door from the underside of the unit by pushing in the finger tab and lifting the door up and away from the compartment.
2. With the door off, turn the unit right side up and the battery pack will fall into hand. Note: The battery pack is connected to the base unit by a cable.

At this point you can either disconnect the battery pack entirely by uncoupling the black connector, or allow it to remain tethered while you replace the batteries.

3. Following the pattern on the battery pack, insert all 8 AA batteries.
4. Reinsert the battery pack, making sure to position the wire correctly, and replace the door.

Please do not mix new and old batteries.

Using Your SoClean 2 Go

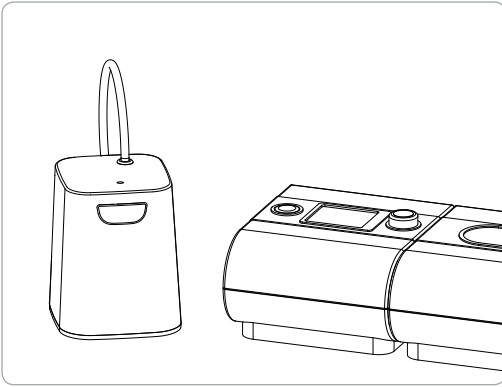

The SoClean 2 Go sanitizes by pumping activated oxygen into your humidifier reservoir and through your CPAP hose. It then passes through your mask into the mask bag, where it sanitizes your mask inside and out. Finally, it exits the mask bag by passing through a filter that converts it into ordinary oxygen.

All this is done without messy solutions, or the need to disassemble any of your equipment.

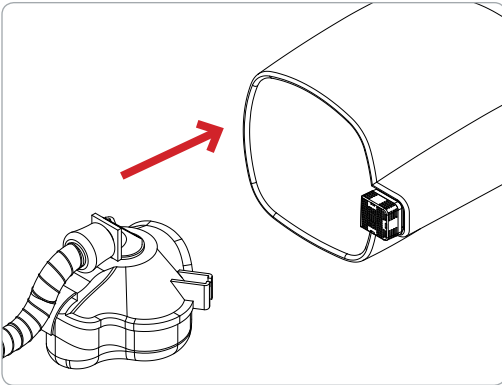

1. While still connected to your CPAP hose, place the CPAP mask fully into the mask bag.

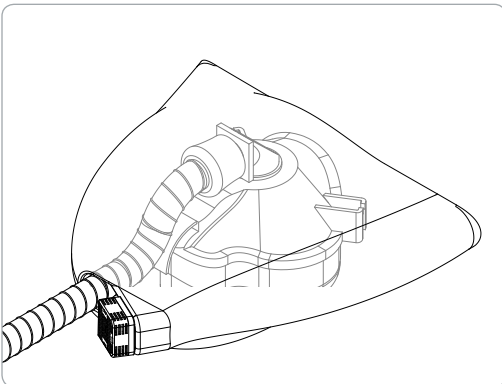

2. Pull the drawstrings so the bag closes tightly around the hose.

Using Your SoClean 2 Go *continued*

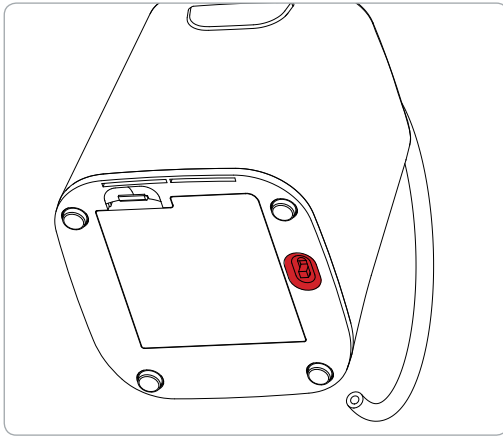

3. Turn on the Power switch located on the underside of the unit. A Green LED will flash on the top of the unit for 30 seconds.

4. Within 30 seconds, press the button above the SoClean 2 Go logo to begin sanitizing. The LED will be solid Green.

If the Start button is not pushed within the 30 seconds while the Green LED is flashing, reset the unit by turning the Power button Off and On to begin the process again.

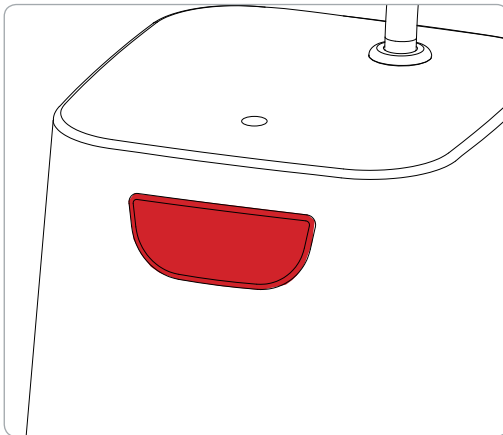

Each time a cycle has run, you should turn off the unit, as it will not run another cycle until the Power button has been turned Off and then back On. This is a safety reset.

If the LED is Red it means the batteries need to be replaced / recharged. The unit will not run.

If the LED turns Red during the cycle it will finish the cycle but the batteries will need to be replaced / recharged before the next use.

Note: The SoClean 2 Go can be turned off at any time during its operation by flipping the Power switch on the underside of the unit.

The SoClean 2 Go is preset to turn off after a 7-minute sanitizing cycle. After this cycle, it is recommended that the mask be left in the mask bag for another 2 hours to achieve maximum sanitizing.

Maintaining Your SoClean 2 Go

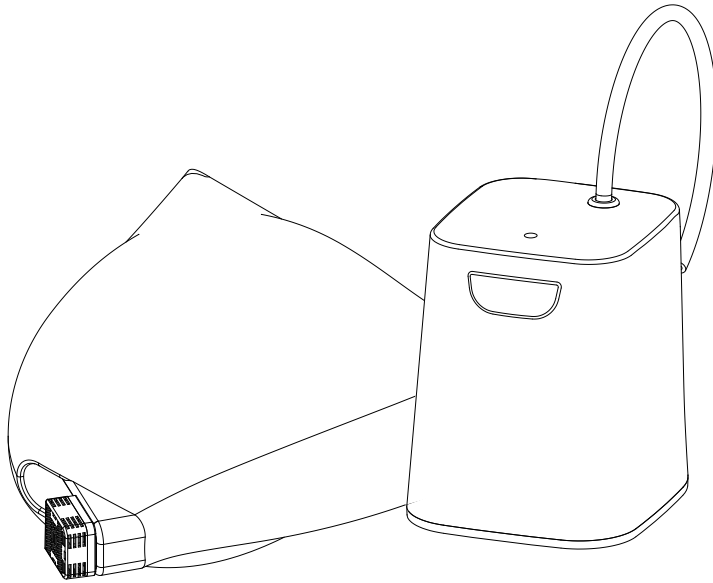

Keep your SoClean 2 Go dust free by periodically wiping it down with a damp cloth. If the bag becomes soiled you may hand wash it and allow it to air-dry. Do not machine wash or machine dry the bag.

The SoClean check valve assembly and filter cartridge should be replaced every 6 months.

Visit your authorized distributor or www.BetterRestSolutions.com to purchase a Cartridge Filter Kit.

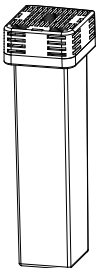

Cartridge Filter
REPLACE EVERY 6 MONTHS

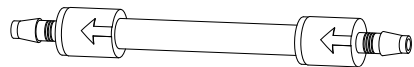

Check Valve Assembly
REPLACE EVERY 6 MONTHS

FAQs

1. Will my CPAP equipment be wet from the SoClean 2 Go? No. The SoClean 2 Go uses no fluids in its operation. It sanitizes with activated oxygen. No fluids or water are used in this process.

2. Is the SoClean 2 Go harmful to me or the environment? No. The activated oxygen it generates is always kept to a safe level. Further, a special filter converts it into ordinary oxygen as it's released from the system.

3. What if the scent the SoClean 2 Go leaves is too strong for me? If you have already treated your equipment with the Neutralizing Pre-Wash, and still feel that the scent is too strong, there are a number of things you can do: (1) Before wearing your mask at bedtime, run your CPAP for 20 seconds to allow any residual scent to be blown out. (2) Run the SoClean 2 Go earlier in the day, allowing any residual scent to dissipate by nighttime. (3) Sanitize your equipment every other day instead of daily.

4. Can I wash my mask bag? The mask bag can be hand-washed and air-dried if necessary.

5. Can I use rechargeable batteries in my SoClean 2 Go? Yes. Any AA batteries will work in the SoClean 2 Go.

6. Are there materials that I should avoid putting into the SoClean 2 Go? Yes. Nylon and natural rubber break down when exposed to activated oxygen. Most CPAP equipment manufacturers typically do not use these materials in their reservoirs, hoses, masks, or headgear. If you have questions about this, contact the manufacturer or Better Rest Solutions.

7. My mask feels oily, what should I do? Skin chemistry is unique. Some individuals with an oily skin type may need to hand-wash the mask occasionally.

For further questions or concerns, please feel free to search our website www.BetterRestSolutions.com, or contact us at 866-501-3705.

Notes

USER GUIDE

**For more information about
SoClean 2 Go
or our other innovative products, please visit
www.BetterRestSolutions.com**

Copyright © 2014
www.BetterRestSolutions.com
is a division of Inceptus, Inc.
SoClean™ is a trademark of Inceptus, Inc.
Uxbridge, MA 01569-2001

Edition Rev. A